



# PTT60

## Pedestrian Tow Tractor

Improve safety and productivity by reducing the strain involved in the transport of common industrial carts.



### TOWING CAPACITY

6,000 lbs.

### BATTERY

**Integrated 205AH lithium battery** and 120vac charger. Support for optional external 240vac charger for greatly reduced charging times. SB175 connector

### TRAVEL SPEED

Variable from 0 mph to 3.4 mph empty  
Variable from 0 mph to 3.1 mph loaded

### WEIGHT

1,875 lbs.

### TIRES / CASTERS

DRIVE

- (1) 9" x 2.95" polyurethane Load Wheels
- (2) 8" x 2.99" polyurethane

### DRIVE

24-Volt AC with **electronic power steering**

### BRAKE

Electromagnetic brake

### CONTROLS & FEATURES

Powered tow hitch elevating system with adjustable mounting plate supports hitch heights from from 6.9" to 12.4" from floor level and delivers a lift stroke of 4.5". Standard pin style pin connection supports integration with many common types of industrial carts.

Ergonomic control head with wrap around hand guard, dual butterfly travel controls with infinitely variable forward and reverse travel control, reversing switch, key switch, battery discharge indicator and horn as standard equipment.

### OPTIONS

- Ball, Clevis, Frame grab, and other custom hitch tools
- Traction Drive Tire
- External 240/1/60 Charger for faster opportunity and full cycle charging

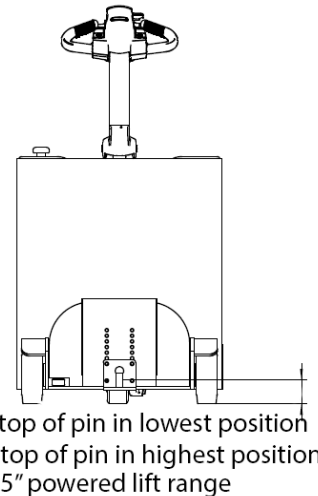
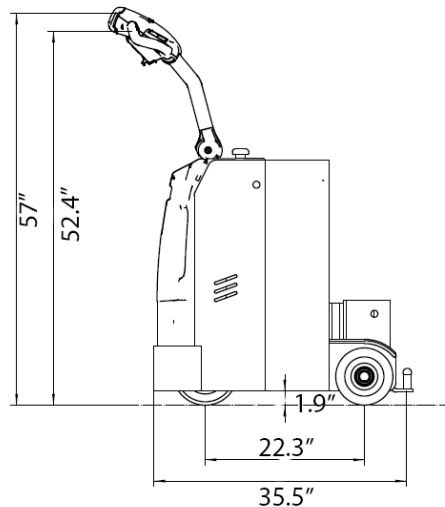

Turning radius 29"

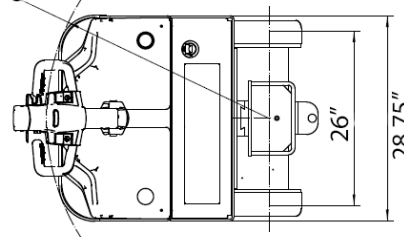

### Maximum gradeability

3% Loaded  
15% Unloaded